



Design/System/Construction/Assembly Usage Disclaimer

- Authorities Having Jurisdiction should be consulted in all cases as to the particular requirements covering the installation and use of UL Certified products, equipment, system, devices, and materials.
- Fire resistance assemblies and products are developed by the design submitter and have been investigated by UL for compliance with applicable requirements. The published information cannot always address every construction nuance encountered in the field.
- When field issues arise, it is recommended the first contact for assistance be the technical service staff provided by the product manufacturer noted for the design. Users of fire resistance assemblies are advised to consult the general Guide Information for each product category and each group of assemblies. The Guide Information includes specifics concerning alternate materials and alternate methods of construction.
- Only products which bear UL's Mark are considered Certified.

BXUV - Fire Resistance Ratings - ANSI/UL 263 Certified for United States
BXUV7 - Fire Resistance Ratings - CAN/ULC-S101 Certified for Canada

Design No. V335

January 18, 2023

Bearing Wall Rating — 1 Hr Rating Exposed to Fire on Exterior Face (See Item 8)

Bearing Wall Rating — 2 Hr Rating Exposed to Fire on Interior Face

Finish Rating — 52 min with Item 2
Finish Rating – 54 min with Item 2A

Loaded Per 2018 NDS Supplement, ASD Method, Wall Braced Mid-Height

* Indicates such products shall bear the UL or cUL Certification Mark for jurisdictions employing the UL or cUL Certification (such as Canada), respectively.

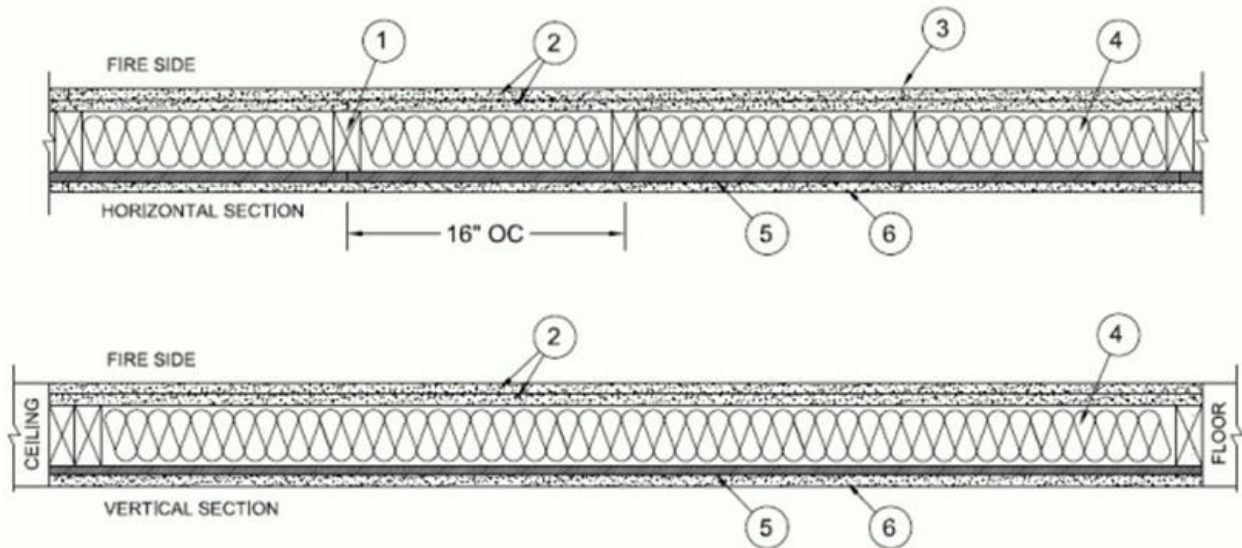

- 1. Structural Wood Members*** — Pressure-treated, fire-retardant wood studs - nominal 2 by 4 in., spaced 16 in. OC effectively fire stopped. As an option, nominal 2 x 6 in. pressure treated, fire-retardant wood studs spaced 24 in. OC. **VIANCE, LLC — D-BLAZE® treated lumber**
- 2. Gypsum Board*** — Any 5/8 in. thick UL Classified Gypsum Board that is eligible for use in Design Nos. L501, G512, or U305 - Nom 5/8 in. thick, 4 ft. wide, two layers applied vertically. Base layer nailed to wood studs and bearing plates 6 in. OC. with 6d cement coated nails, 1-7/8 in. long, 0.0915 in. shank diam. and 1/4 in. diam. head. The face layer, with joints staggered from base layer, nailed to the studs and bearing plates over the base layer, 8 in. OC with 8d cement coated nails, 2-3/8 in. long, 0.113 in. shank diam. 9/32 in. diam. head. See Gypsum Board * (CKNX) category for a list of Classified Manufacturers.

2A. Gypsum Board* — For use with Item 4B — 5/8 in. thick, 4 ft wide, two layers applied vertically. Base layer fastened to wood studs and bearing plates 6 in. OC with #6 1-5/8 in. long screws. The face layer, with joints staggered from the base layer, fastened to the studs and bearing plates over the base layer, 8 in. OC with #6 2 in. long screws. **NATIONAL GYPSUM – Type FSW-C**
- 3. Joints and Nail heads** — Gypsum board joints covered with tape and joint compound. Nail heads covered with joint compound.
- 4. Batts and Blankets*** — For use with Item 7 – Faced or unfaced mineral fiber or fiberglass insulation 3-1/2 in. thick, min 1.46 pcf (min R-13 thermal insulation rating), pressure fit in the wall cavity between 2 x 4 in. studs, plates, and cross bracing. 5-1/2 in. thick, min 1.46 pcf (min R-13 thermal insulation rating), pressure fit in the wall cavity between 2 x 6 in. studs, plates, and cross bracing. Insulation may be applied in multiple layers to achieve final thickness. See **Batts and Blankets*** (BZJZ) category for names of Classified manufacturers.

4A. Batts and Blankets* — For use with Item 6 — Faced or unfaced mineral wool insulation, 3-1/2 in. thick, min 3.0 pcf, friction fit in the wall cavity between the studs, plates and cross bracing. 5-1/2 in. thick, min 3.0 pcf, pressure fit in the wall cavity between 2 x 6 in. studs, plates, and cross bracing. Insulation may be applied in multiple layers to achieve final thickness. See **Batts and Blankets*** (BZJZ) category for names of Classified manufacturers.

4B. Batts and Blankets* — For use with Item 6 — Faced or unfaced fiberglass insulation 3-1/2 in. thick, min 0.8 pcf (min R-13 thermal insulation rating), pressure fit in the wall cavity between 2 x 4 in. studs, plates, and cross bracing. 5-1/2 in. thick, min 0.8 pcf (min R-13 thermal insulation rating), pressure fit in the wall cavity between 2 x 6 in. studs, plates, and cross bracing. Insulation may be

applied in multiple layers to achieve final thickness. See **Batts and Blankets*** (BZJZ) category for names of Classified manufacturers.

5. Structural Wood Members* — Pressure-treated, fire-retardant plywood installed vertically nailed to the wood framing with 1-7/8 in. long, 6d nails, spaced 6 in. OC. on the perimeter and 12 in. OC. in the field. Vertical and horizontal joints are backed by framing. Panels provided in nominal size of 48 in. wide by 96 in. long by 15/32 in. thick. **VIANCE, LLC — D-BLAZE® treated plywood**

5A. Foamed Plastic* — (Optional) — **For use with Item 5** — Foamed plastic boards, faced or unfaced, may or may not be bonded to fiberboard, plywood or OSB and placed between Structural Wood Members, (Item 5) and Exterior Facings (Item 6, Item 7, or Item 8). See **Foamed Plastic*** (CCVW) category for names of Classified manufacturers.

6-6F. Exterior Facings — For use with Item 4A and 4B — Any exterior facing, as authorized by the Authority having Jurisdiction and installed in accordance with the manufacturer's installation instructions. Exterior facings may include but are not limited to:

6A. Molded Plastic — Solid vinyl siding mechanically secured to framing members in accordance with manufacturer's recommended installation details.

6B. Brick — Minimum 2.7 in. thick solid brick or 2.3 in. hollow brick, meeting the requirements of local code agencies. Brick attached to the studs with corrugated metal wall ties attached to each stud with 8d cement coated nails, every sixth course of bricks.

6C. Particle Board Siding — Oriented strand board, wafer board, or hard board exterior building sidings including patterned panels.

6D. Plywood — American Plywood Association rated siding including T1-11 and series 303 textures, rough sawn, MDO, brushed, channel grooved, and lap siding.

6E. Cement Plaster — Minimum 3/4 in. thick cement plaster (1:4 ratio of cement to sand for scratch coat and 1:5 ratio for brown coat with self-furring metal lath or adhesive base coat).

6F. Fiber Cement Siding — Fiber Cement Lap or Vertical Siding. Minimum 5/16 in. thick, fastened to studs through the Building Units, Item 5, with nails or screws, at the locations specified by the manufacturer.

7. Exterior Facings — (Not Shown) — For use with Item 4, Required for 2 Hour Rating on the Interior Face — The following exterior facing shall be installed in accordance with the manufacturer's installation instructions:

7A. Brick — Minimum thickness of 2.3 in. hollow brick or minimum 2.7 in. solid brick, meeting the requirements of local code agencies. Brick attached to the studs with corrugated metal wall ties attached to each stud with 8d cement coated nails, every sixth course of bricks.

8. Exterior Facings — (Not Shown) — Required for 1 Hour Rating on the Exterior Face. The following exterior facing shall be installed in accordance with the manufacturer's installation instructions:

8A. Brick — Minimum thickness of 2.7 in. of solid brick or minimum 2.3 in. of hollow brick, meeting the requirements of local code agencies. Brick attached to the studs with corrugated metal wall ties attached to each stud with 8d cement coated nails, every sixth course of bricks.

8B. Cement Plaster — Portland cement with self-furring metal lath. Minimum thickness of 3/4 in. with a mix ratio of 1:4 for scratch coat and 1:5 for brown coat, by volume, cement to sand.

Last Updated on 2023-01-18